

NEPTUNE®

Stone-based Waterproof Floors

Australiana



- ✓ 17% better scratch resistance than standard UV Coating (ISO1518)
- ✓ 28% better stain resistance than standard UV Coating (EN438-2)

Sentinel Scratch Resistant Finish

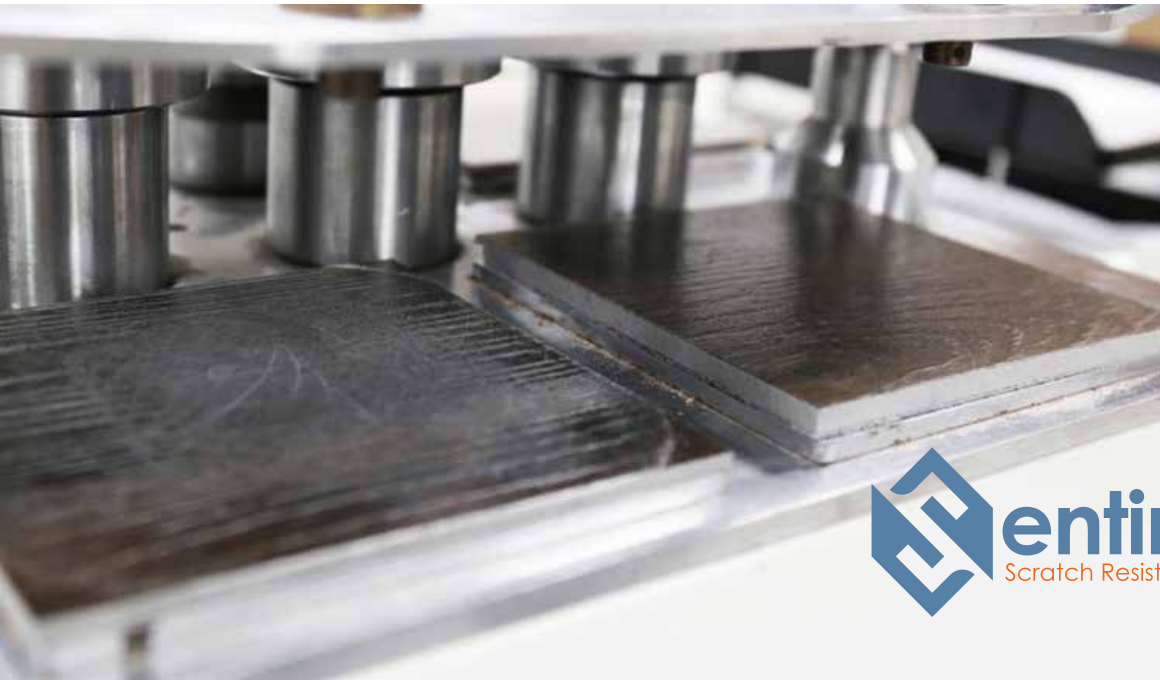

Taken after 1000 revolutions at 32N



Scratch

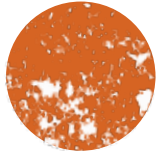

Wear



Stain

EXTRA WEAR & STAIN RESISTANCE

While many coatings currently available on Rigid products help with one of these features, Sentinel brings the possibility for Rigid to perform better on all fronts.

Sentinel outperforms all other common competitive flooring finishes in the 3 areas that really matter when it comes to coatings.

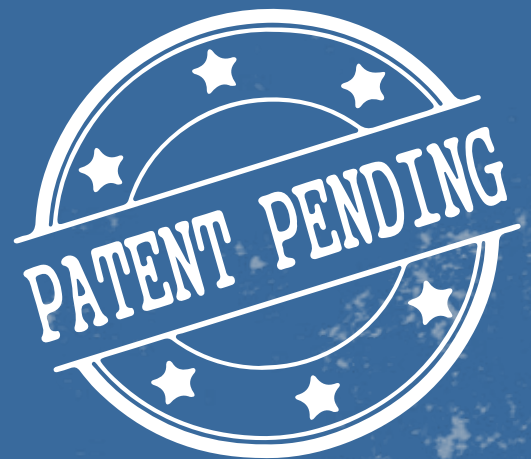

Neptune Flooring Features:

- ➔ 100% waterproof: Perfect for places that are prone to spills
- ➔ Stable to high temperature variations and direct sunlight
- ➔ Fast, easy and clean installation in no time thanks to its tight lock click system
- ➔ Minimum subfloor preparation
- ➔ Floor for all seasons
- ➔ Seamless large area installation up to 400 m²
- ➔ Easy to clean & maintain
- ➔ Quiet, soft and warm underfoot
- ➔ Safe & environmentally friendly: 100% free of Ortho-Phthalates & other harmful substances
- ➔ Kid & pet friendly

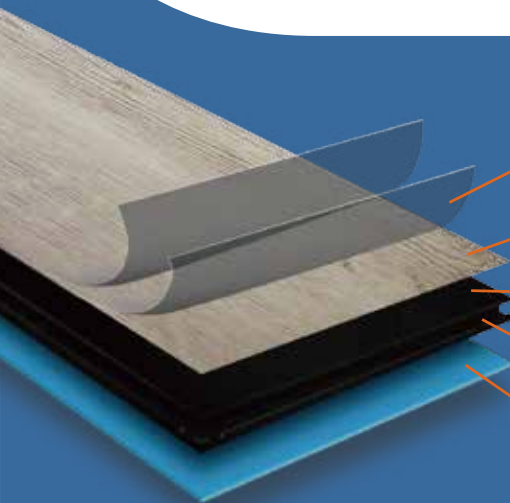

MULTI LAYER PROTECTIVE COATING

For extra protection against heavy foot traffic, scuffs and stains

DEEP STRUCTURED DECORATIVE LAYER

Giving Neptune the look & feel of hardwood

STONE-BASED SOLID CORE

100% Waterproof | Stable & Rigid | Dent Resistant | Ortho-phthalates Free

TIGHT LOCK CLICK SYSTEM

For fast & Easy Installation

PRE-ATTACHED SOUND ABSORBING PAD

For extra protection, sound absorption & an extra soft underfoot



STABLE

- Durable construction
- Waterproof



100%
Waterproof



Easy
Maintenance

RIGID

- Superior indentation resistance
- No telegraphing of small subfloor imperfections



Extra Impact
Resistant Surface

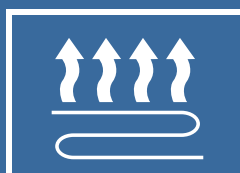

Suitable For
Underfloor Heating

FLOATING INSTALLATION

- Easy-to-install click system
- Installs over most existing subfloors



HEALTH & SUSTAINABILITY

Health & sustainability are the No.1 priorities. We ensure that Neptune® floors are safe for you, your family, and the environment.

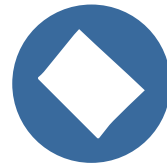

Extra Rigid Limestone-Based Core



100% Free Of: Ortho-Phthalates and Other Harmful Substances



100% Recyclable

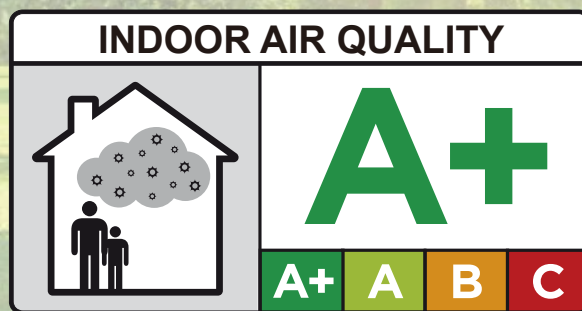

Size: 1620 x 146 x 5.5mm (incl. 1mm Sound Absorbing Pad)

Wear layer: 0.55mm

Surface: Natural Wood Grain

Bevel: Bevel on 4 Sides

Click: Tight Lock

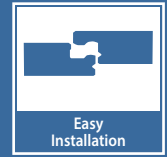
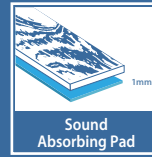

Colour illustrations are indicative only. Actual product may vary due to batch variations or display limitations.



SG CURRUMBIN



BB SCARBOROUGH



BB SORRENTO



NORTHERN RIVER GUM

Size: 1620 x 146 x 5.5mm (incl. 1mm Sound Absorbing Pad)

Wear layer: 0.55mm

Surface: Natural Wood Grain

Bevel: Bevel on 4 Sides

Click: Tight Lock

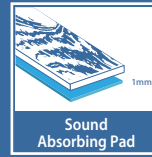

Colour illustrations are indicative only. Actual product may vary due to batch variations or display limitations.



SG PORTSEA



SG FRESHWATER



BB BRIGHTON



KINGS PARK JARRAH

Water Resistant Flooring Accessories

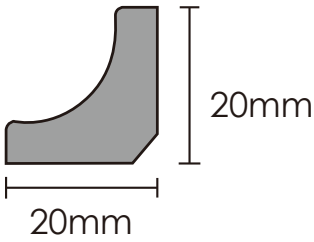
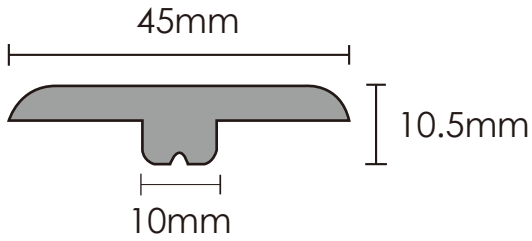
Scotia	T-Mould
	
Dimensions:	Dimensions:
15 x 28 x 2400 mm	10.5 x 45 x 2400 mm

Our Flooring accessories are available in all hybrid plank colours

SG CURRUMBIN
 SG PORTSEA
 BB SCARBOROUGH
 SG FRESHWATER
 BB SORRENTO
 BB BRIGHTON
 NORTHERN RIVER GUM
 KINGS PARK JARRAH

Neptune® Room Visualiser



The most advanced AR computer vision tech used to change the floor anywhere in 3 clicks!



Try our quick and easy
Neptune® Room Visualizer

EXCLUSIVE TO
Harvey Norman®



NEPTUNE®

Stone-based Waterproof Floors

Australiana



FOLLOW US



www.neptune-flooring.com